

MITSUBISHI RF POWER TRANSISTOR

2SC3133

NPN EPITAXIAL PLANAR TYPE

DISCRIPTION

2SC3133 is a silicon NPN epitaxial planar type transistor designed for RF power amplifiers in HF band mobile radio applications.

FEATURES

- High power gain: $G_{pe} \geq 14\text{dB}$
@f = 27MHz, $V_{CC} = 12\text{V}$, $P_o = 13\text{W}$
- Emitter ballasted construction for high reliability and good performances.
- High ruggedness: The ability withstand infinite VSWR when operated at f = 27MHz, $P_o = 16\text{W}$, $V_{CC} = 16\text{V}$.
- Intermodulation distortion: $\text{IMD} \leq -25\text{dB}$
@f = 27MHz, $V_{CC} = 12\text{V}$, $P_o = 13\text{W}$ (PEP)
- Input/output impedance:
 $Z_{in} = 1.8 - j2.5(\Omega)$, $Z_{out} = 7.0 - j3.5(\Omega)$
@f = 27MHz, $V_{CC} = 12\text{V}$, $P_o = 13\text{W}$

APPLICATION

10 watts output power amplifiers in HF band SSB mobile radio application.

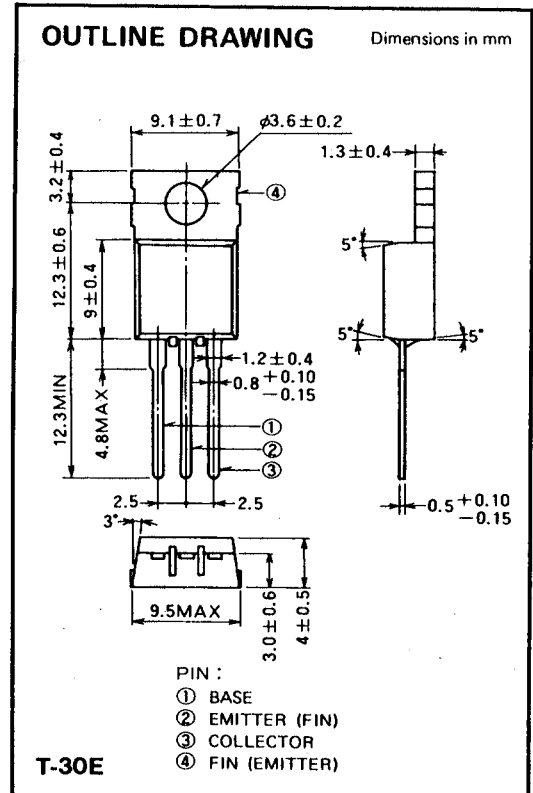

ABSOLUTE MAXIMUM RATINGS ($T_C = 25^\circ\text{C}$ unless otherwise specified)

Symbol	Parameter	Conditions	Ratings	Unit
V_{CBO}	Collector to base voltage		60	V
V_{EBO}	Emitter to base voltage		5	V
V_{CEO}	Collector to emitter voltage	$R_{BE} = \infty$	25	V
I_C	Collector current		6	A
P_C	Collector dissipation	$T_a = 25^\circ\text{C}$	1.5	W
		$T_C = 25^\circ\text{C}$	20	W
T_j	Junction temperature		150	$^\circ\text{C}$
T_{stg}	Storage temperature		-55 to 150	$^\circ\text{C}$
R_{th-a}	Thermal resistance	Junction to ambient	83.3	$^\circ\text{C/W}$
R_{th-c}		Junction to case	6.25	$^\circ\text{C/W}$

Note. Above parameters are guaranteed independently.

ELECTRICAL CHARACTERISTICS ($T_C = 25^\circ\text{C}$ unless otherwise specified)

Symbol	Parameter	Test conditions	Limits			Unit
			Min	Typ	Max	
$V_{(BR)EBO}$	Emitter to base breakdown voltage	$I_E = 1\text{mA}$, $I_C = 0$	5			V
$V_{(BR)CBO}$	Collector to base breakdown voltage	$I_C = 5\text{mA}$, $I_E = 0$	60			V
$V_{(BR)CEO}$	Collector to emitter breakdown voltage	$I_C = 10\text{mA}$, $R_{BE} = \infty$	25			V
I_{CBO}	Collector cutoff current	$V_{CB} = 30\text{V}$, $I_E = 0$			500	μA
I_{EBO}	Emitter cutoff current	$V_{EB} = 4\text{V}$, $I_C = 0$			500	μA
h_{FE}	DC current gain*	$V_{CE} = 12\text{V}$, $I_C = 10\text{mA}$	10	50	180	—
P_o	Output power	$f = 27\text{MHz}$, $V_{CC} = 12\text{V}$, $P_{in} = 0.5\text{W}$	13	16		W
η_C	Collector efficiency		60	70		%

Note. *Pulse test, $P_W = 150\mu\text{s}$, duty = 5%.

Above parameters, ratings, limits and conditions are subject to change.

TEST CIRCUIT

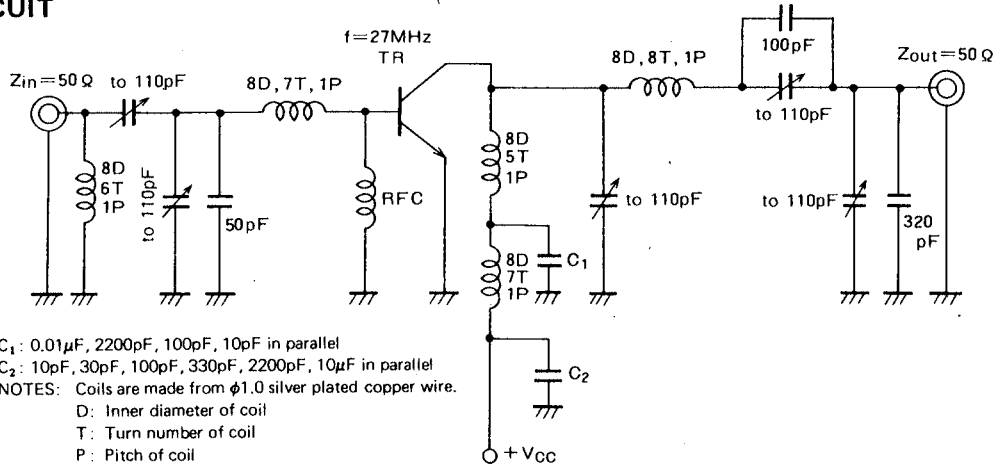

TYPICAL PERFORMANCE DATE

COLLECTOR DISSIPATION VS. AMBIENT TEMPERATURE

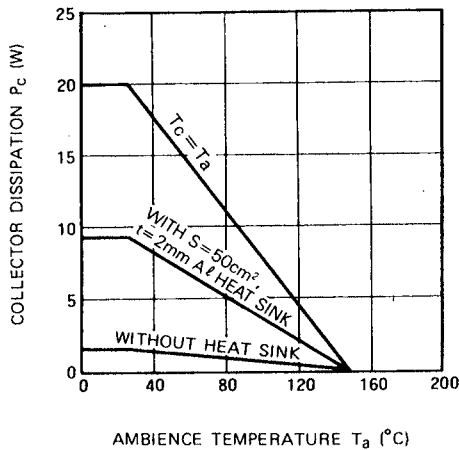

COLLECTOR CURRENT VS. COLLECTOR TO EMITTER VOLTAGE

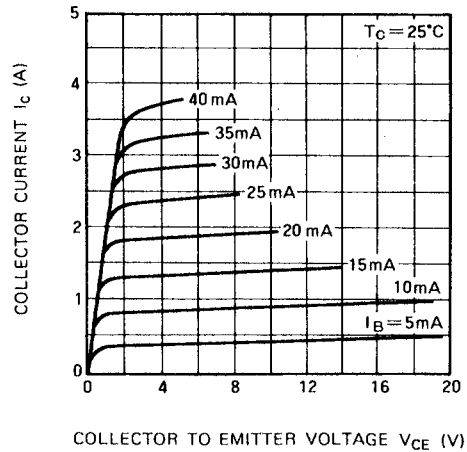

DC CURRENT GAIN VS. COLLECTOR CURRENT

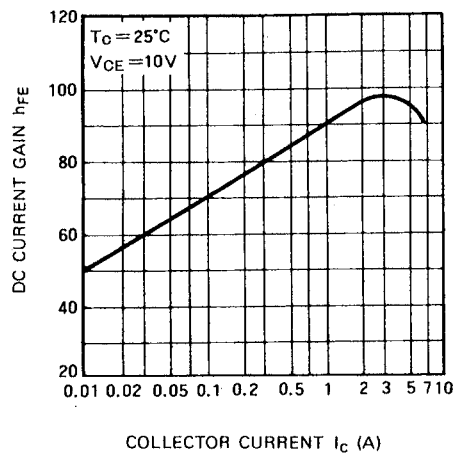

COLLECTOR TO EMITTER BREAKDOWN VOLTAGE VS. BASE TO EMITTER RESISTANCE

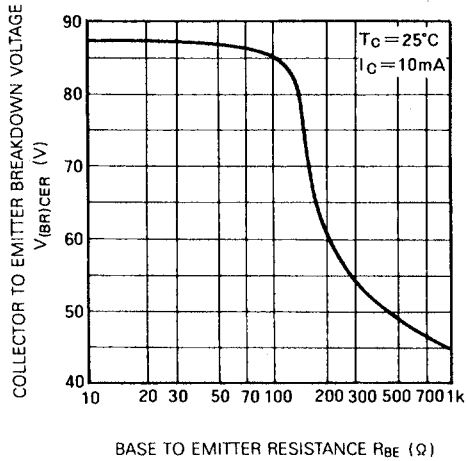

MITSUBISHI RF POWER TRANSISTOR
2SC3133

NPN EPITAXIAL PLANAR TYPE

COLLECTOR OUTPUT CAPACITANCE VS. COLLECTOR TO BASE VOLTAGE

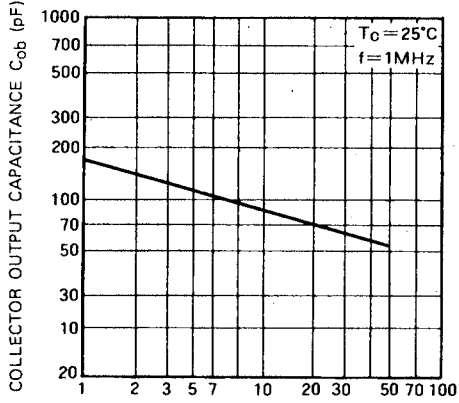

COLLECTOR TO BASE VOLTAGE V_{CB} (V)

OUTPUT POWER, COLLECTOR EFFICIENCY VS. INPUT POWER

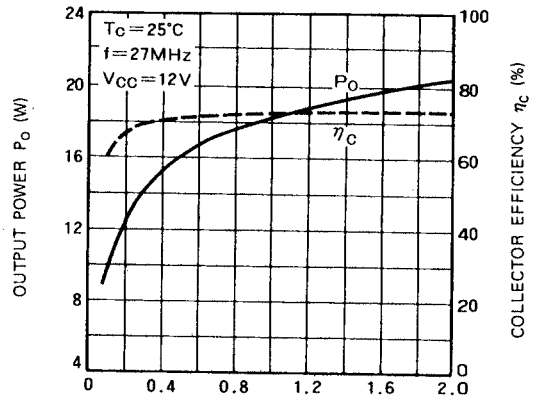

INPUT POWER P_{in} (W)

OUTPUT POWER VS. COLLECTOR SUPPLY VOLTAGE

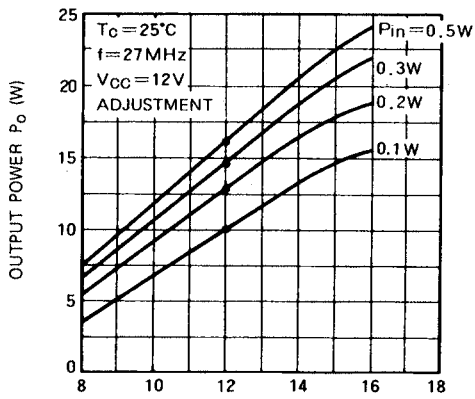

COLLECTOR SUPPLY VOLTAGE V_{CC} (V)